

MyBlock – nFollow Distance

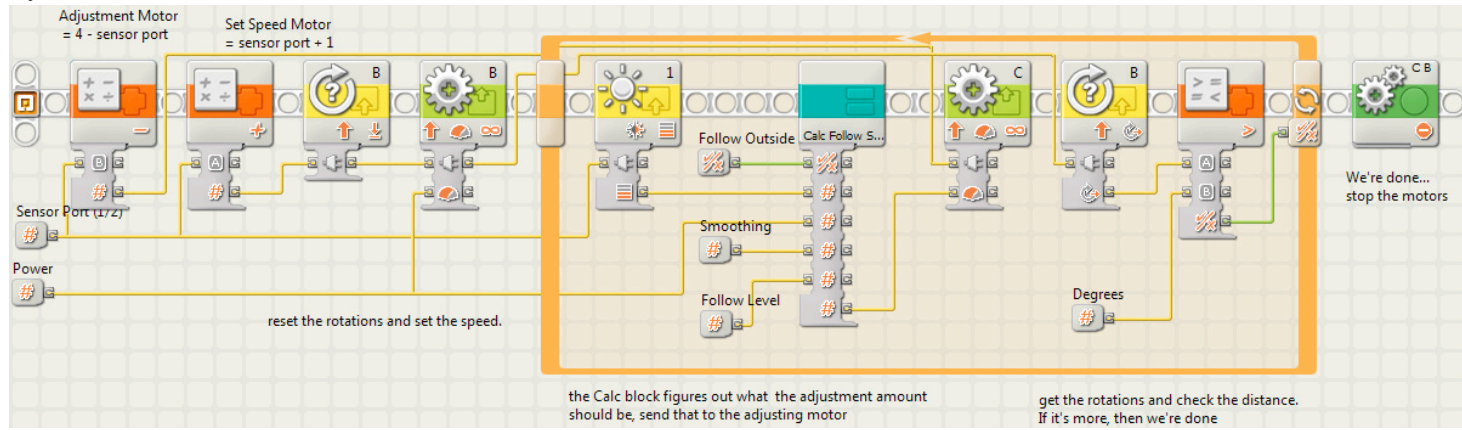

MyBlock – nFollow To Line

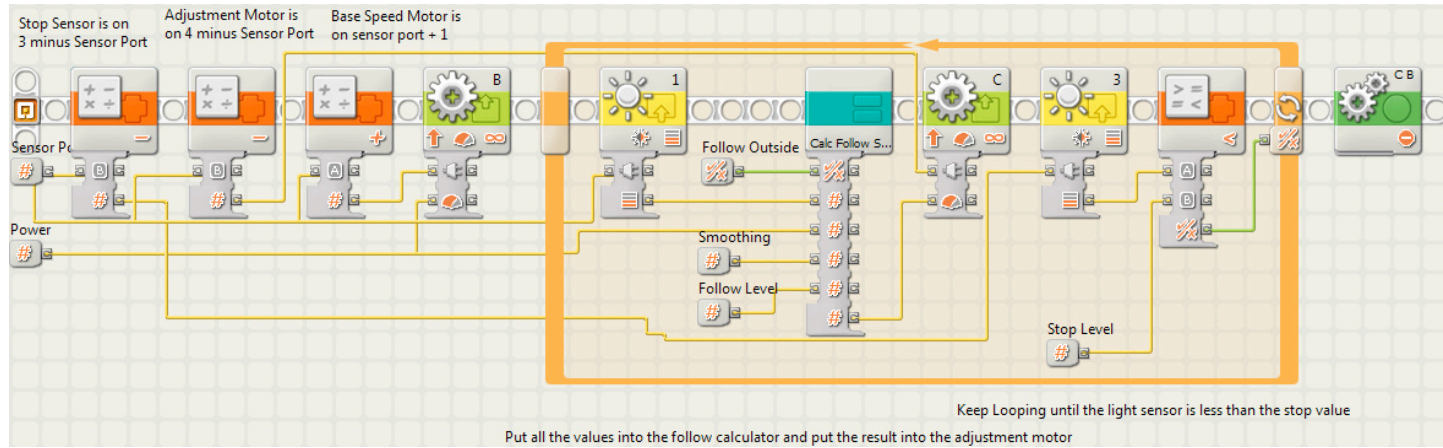

MyBlock – nFollow Time

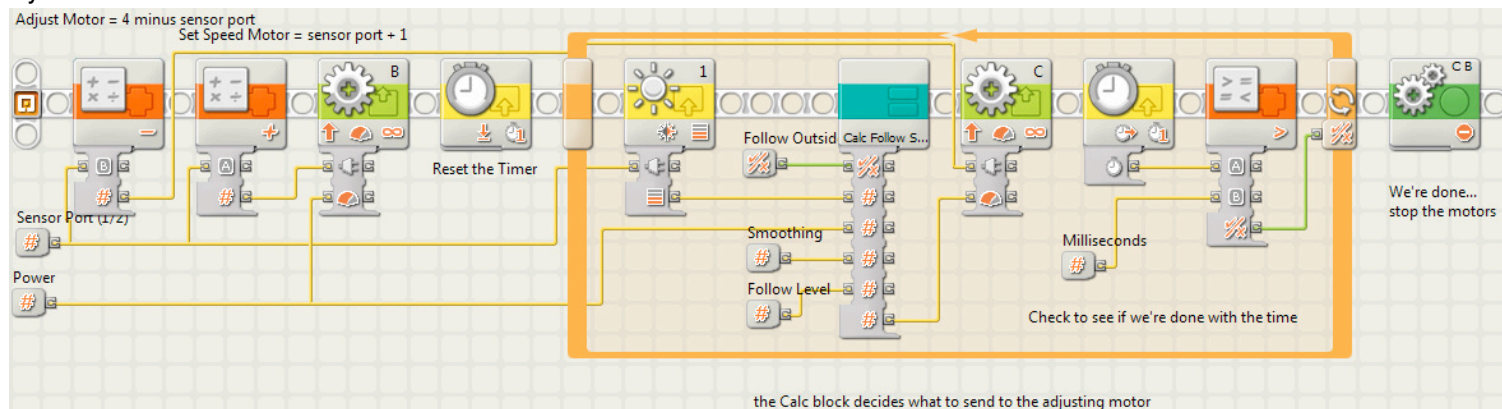

MyBlock – Calc Follow Speed (Used inside the Line Following MyBlocks)

